

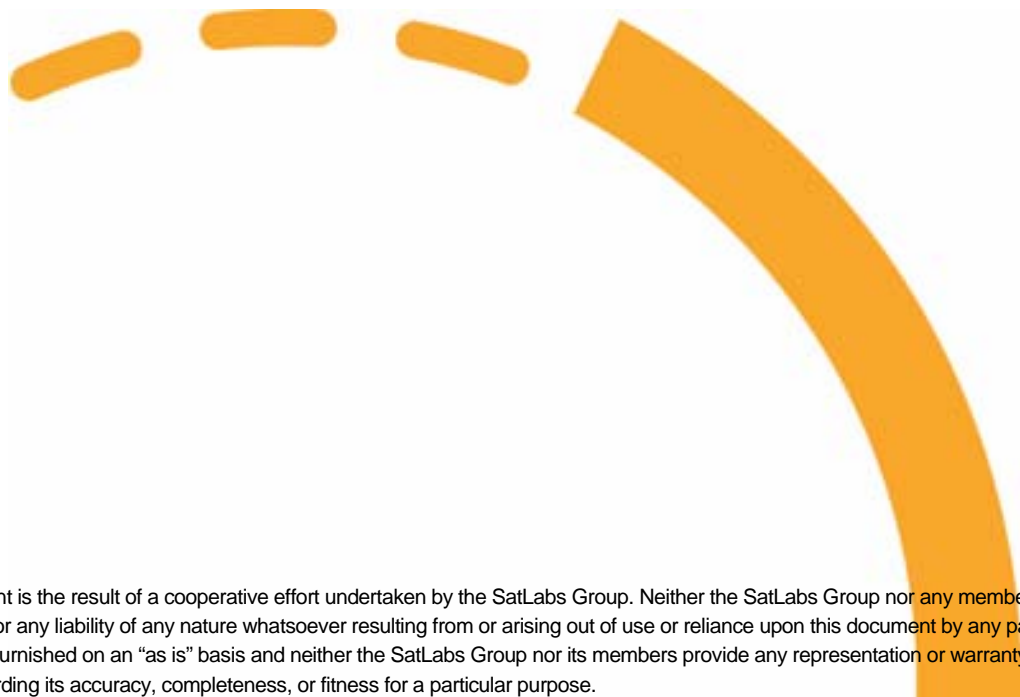

# SatLabs System Recommendations

Version 1.3

June 2008



This document is the result of a cooperative effort undertaken by the SatLabs Group. Neither the SatLabs Group nor any member organisation is responsible for any liability of any nature whatsoever resulting from or arising out of use or reliance upon this document by any party. This document is furnished on an "as is" basis and neither the SatLabs Group nor its members provide any representation or warranty, express or implied, regarding its accuracy, completeness, or fitness for a particular purpose.

## Document history

Revision	Date	Changes
1.1	03-07-2003	First version
1.2	02-12-2005	Updated version defining the SatLabs Qualification programme baseline
1.3	10-06-2008	Defining Version 1.3 recommendations.

Editor: Stephane Combes, ESA/ESTEC ([stephane.combes@esa.int](mailto:stephane.combes@esa.int))

Inquiries related to the SatLabs Group should be directed to:

Xavier Lobao Pujolar - Chairman SatLabs Group

ESTEC P.O. Box 299  
Noordwijk 2200 AG  
Netherlands

Email: [info@satlabs.org](mailto:info@satlabs.org)  
Phone: +31 (0) 7156 53641  
Fax: +31 (0) 7156 54093

Web site: [www.satlabs.org](http://www.satlabs.org)

## Table of Contents

<b>1</b>	<b>Preface.....</b>	<b>7</b>
<b>2</b>	<b>Scope .....</b>	<b>8</b>
<b>3</b>	<b>References.....</b>	<b>10</b>
<b>4</b>	<b>Definitions, symbols and abbreviations.....</b>	<b>11</b>
4.1	Definitions .....	11
4.1.1	<i>Compliance</i> .....	11
4.1.2	<i>Interoperability</i> .....	11
4.1.3	<i>Certification</i> .....	12
4.1.4	<i>Qualification</i> .....	12
4.1.5	<i>Services outside the scope</i> .....	12
4.1.6	<i>SatLabs Terminal Profiles</i> .....	12
4.1.7	<i>General definitions</i> .....	12
4.2	Abbreviations.....	13
<b>5</b>	<b>Reference architecture.....</b>	<b>15</b>
5.1	Baseline DVB-RCS network .....	15
5.2	Terminal architecture .....	16
<b>6</b>	<b>Technical Recommendations.....</b>	<b>17</b>
6.1	Introduction.....	17
6.2	Basic IP service recommendations .....	18
6.2.1	<i>IP services</i> .....	18
6.2.2	<i>Multicast</i> .....	18
6.2.3	<i>Enhanced Quality of Service support</i> .....	18
6.2.4	<i>Interoperable Performance Enhancement Proxy support</i> .....	19
6.2.5	<i>HTTP pre-fetching support</i> .....	19
6.3	DVB-RCS specifications outside current scope.....	21
6.3.1	<i>General</i> .....	21
6.3.2	<i>SNMP</i> .....	21
6.4	DVB-RCS interoperability recommendations .....	22
6.4.1	<i>Introduction</i> .....	22
6.4.2	<i>Network Control</i> .....	22
6.4.2.1	<i>Introduction</i> .....	22
6.4.2.2	<i>Forward link signalling</i> .....	22
6.4.2.3	<i>Return Interaction Path Descriptor</i> .....	23

6.4.2.4	TIM RCST status bits .....	24
6.4.2.5	Behaviour of RCST after reception of log-off in RCST status field .....	25
6.4.2.6	CSC burst contents .....	25
6.4.2.7	Configurable terminal parameters .....	26
6.4.2.8	ACQ and SYNC Reply Timeout .....	27
6.4.2.9	SYNC burst contents .....	27
6.4.3	<i>SAC</i> .....	27
6.4.3.1	SAC field length .....	27
6.4.3.2	Channel ID .....	27
6.4.3.3	Fine Sync Achieved message .....	27
6.4.4	<i>Terminal capacity requests</i> .....	27
6.4.4.1	General .....	27
6.4.4.2	RBDC .....	27
6.4.5	<i>Return Link Variability</i> .....	28
6.4.6	<i>Turbo code permutation (New permutations)</i> .....	29
6.4.7	<i>Time to remain in non-operational states</i> .....	29
6.4.8	<i>Reference timing</i> .....	29
6.4.8.1	NCR Reference Plane .....	29
6.4.8.2	NCR Optional Payload .....	29
6.4.8.3	RCST internal delay compensation .....	30
6.4.8.4	SPT table contents in the Qualification testing Test bed .....	31
6.4.8.5	Superframe start time signalled in SCT .....	31
6.4.9	<i>DSM-CC Encapsulation and Section Packing</i> .....	31
6.4.9.1	Encapsulation .....	32
6.4.9.2	Section packing .....	32
6.4.10	<i>Slow Hopping</i> .....	32
6.4.11	<i>Return Link Code Rates</i> .....	32
6.4.12	<i>Return Link Symbol Rate Granularity</i> .....	32
6.4.13	<i>Superframe Duration Range</i> .....	32
6.4.14	<i>Fixed MF-TDMA</i> .....	32
6.4.15	<i>Handling of unexpected signalling information</i> .....	33
6.4.16	<i>Handling of the scaling factor related to timing corrections</i> .....	33
6.4.16.1	Common scaling for Correction Message and SYNC/ACQ Assign Descriptors .....	33
6.4.16.2	Independent scaling of burst_time_correction given in CMT .....	33
6.4.16.3	Adjustment of the SYNC_achieved_time_threshold .....	33
6.4.17	<i>DVB-S2 support</i> .....	33
6.5	DVB-RCS extensions .....	35

6.5.1	<i>Introduction</i> .....	35
6.5.2	<i>Control of terminal behaviour</i> .....	35
6.5.3	<i>Quality of Service</i> .....	35
..... <b>Terminal Options and Parameter Ranges</b>		<b>36</b>
<b>7</b>	.....	<b>36</b>
7.1	<i>Introduction</i> .....	36
7.2	<i>Mandatory DVB-RCS options</i> .....	36
7.3	<i>SatLabs Qualification testing options</i> .....	37
7.4	<i>Terminal Configuration</i> .....	39
7.4.1	<i>Introduction</i> .....	39
7.4.2	<i>Parameters Overview</i> .....	39
7.4.3	<i>Baseline Parameters</i> .....	42
7.4.4	<i>ATM parameters</i> .....	46
7.4.5	<i>MPEG Option Parameters</i> .....	47
<b>8</b>	<b>Qualification Testing</b> .....	<b>48</b>
8.1	<i>Introduction</i> .....	48
8.2	<i>Terminal Qualification Test Set-up</i> .....	48
8.3	<i>Test System Interface Specifications</i> .....	50
<b>Appendix A - Definition of the Multicast PID Mapping Table</b> .....		<b>51</b>
<b>Appendix B - NCR optional payload recommendations</b> .....		<b>54</b>
B.1	<i>Background</i> .....	54
B.2	<i>Implementation of the Optional Payload Field in the PCR Insertion TS Packet</i> .....	55

## List of Figures

Figure 5-1: RCST network supporting basic IP services with interfaces labeled according to [5].....	15
Figure 5-2: RCS terminal Interfacility Link .....	16
Figure 6-1: Single Side Pull Architecture .....	20
Figure 6-2: Single Side Pull Example .....	20
Figure 8-1: Qualification test set-ups: - testing of Indoor Unit only - testing of Indoor Unit connected to the Outdoor Unit .....	49

## List of Tables

Table 6-1: Basic IP functionality to be supported by SatLabs compliant terminals .....	18
Table 6-2: Forward Link signalling .....	23
Table 6-3: Return Interaction Path descriptor format .....	24
Table 6-4: TIM RCST status bits.....	25
Table 6-5: CSC burst content .....	26
Table 6-6: Allowed deviation in the timing of the CSC burst transmission .....	31
Table 6-7: DVB-S2 options description.....	34
Table 6-8: Configurable terminal features for SatLabs testing .....	35
Table 7-1: DVB-RCS options supported by all SatLabs compliant terminals.....	36
Table 7-2: DVB-RCS required functionality which is out of SatLabs scope .....	36
Table 7-3: DVB-RCS options that may be supported by SatLabs compliant terminals.....	37
Table 7-4: SatLabs qualification parameter overview .....	42
Table 7-5: SatLabs qualification common parameter values .....	45
Table 7-6: SatLabs qualification parameter values for the Basic ATM profile.....	46
Table 7-7: SatLabs qualification parameter values for the MPEG option.....	47
Table 8-1: Test system interface specifications .....	50
Table A-1: Multicast PID Mapping Table (DVB format).....	51
Table B-1: Syntax of the optional PCR Insertion TS packet payload section.....	55

# 1 Preface

The goal of these Recommendations – SatLabs Systems Recommendations (SSR) - is to facilitate interoperability of DVB-RCS terminals through a qualification system managed by the SatLabs Group:

- *Interoperability* of terminals compliant with SatLabs Terminal Profiles
  - Terminals from different manufacturers that are compliant with the SSR shall be able to operate in networks that support the SSR
- *Documenting compliance* with the DVB-RCS standard and SSR for critical terminal and system interoperability issues

The SatLabs terminal qualification process is limited to documenting the terminal compliance. Hub vendors that are SatLabs members commit to support interoperability with all terminals complying with the SatLabs profile(s) within the Hub's capability.

These Recommendations define SatLabs Terminal Profiles specifying IP services, DVB-RCS options and complementary features to be supported for each SatLabs Terminal Profile. These Recommendations also describe qualification test parameter profiles that will be used in the qualification testing. These profiles are by definition certified interoperable configurations for SatLabs compliant terminals. The scope of the qualification testing is to ensure interoperability of critical air interface protocol issues. The general functionality, capabilities and performance of the terminal are outside the scope of the qualification tests.

## **SatLabs**

SatLabs is an open industry organization working for *compliance* and *interoperability* of DVB-RCS systems. The large number of options and parameters currently allow DVB-RCS implementations that are compliant with the standard but not interoperable. SatLabs believes that the success of the DVB-RCS standard requires the presence of interoperable RCS terminals in the marketplace.

The mission of SatLabs is to complement the DVB-RCS standard with recommendations and guidelines to facilitate DVB-RCS terminal interoperability, and to provide a mechanism for formal DVB-RCS interoperability certification.

## **Commitment from SatLabs members**

These Recommendations describe system and terminal features for interoperable DVB-RCS networks. Hub vendors that are SatLabs members commit to support basic services in compliance with the SatLabs profiles that fall within the Hub's capability. This commitment enables a competitive, interoperable environment for DVB-RCS networks based on the SSR.

## 2 Scope

This document defines the SatLabs System Recommendations (SSR), consisting of basic IP services and DVB-RCS functionality to be supported by hubs and terminals, and corresponding tests to verify the compliance with the Recommendations. Terminals passing these tests can be certified as SatLabs compliant terminals.

Interoperability can be addressed at many levels. The scope for SatLabs terminal interoperability comprises of:

- Support for a defined set of basic IP services
- Focus on the operational aspects of interoperability
- Definition of SatLabs terminal profiles for different levels of terminal functionality
- Definition of complete test sets allowing verification of terminal profile compliance to SatLabs System Recommendations
- Selection of RCS parameters and options as the basis for verification tests for the defined terminal profiles

The present SSR version defines SatLabs terminal profile 1.3 and the associated certification. This Version 1.3 expands the scope of Version 1.2 to include:

- Interoperable QoS functionality
- Enhanced QoS and support, defining the Enhanced QoS option (ENHQOS)
- Interoperable Performance Enhancement Proxy (iPEP) [6], defining the PEP option
- HTTP pre-fetching in a single side pull mode, defining the HTTP option
- Definition of 2 terminal profiles for the support of DVB-S and DVB-S2
- Definition of 2 terminal profiles for DVB-S2: Constant Coding and Modulation (CCM), Variable Coding and Modulation/Adaptive Coding and Modulation (VCM/ACM, which includes CCM support)

SatLabs terminal profile v 'N' or SatLabs Version 'N' certification refer to SSR versions 'N'.

The basis for these Recommendations are the following documents:

- DVB-RCS Specifications [1]
- DVB-RCS Guidelines [2]

The present SSR also considers the following document as applicable:

- SatLabs System Recommendations: QoS specifications [5]

An objective of the SatLabs terminal profile definition is the ability to guarantee a minimum level of interoperability. Therefore the focus is to describe a core of interoperable services and management functions. Operational network implementations may implement enhanced functions and services.

For verification and compliance testing being able to influence terminal behaviour is necessary. These Recommendations define the features required from a SatLabs compliant terminal for such purposes. The ability to enable and disable features may also be relevant in operational environments.

The SatLabs System Recommendations are based on the DVB-RCS Standard ETSI EN 301 790 V1.4.1 (2005-09) [1]. Issues related to compatibility with the previous version of the standard are not addressed unless explicitly stated in this document.

The interface between the IDU and ODU is not specified in [1], although various interface configurations are described as options. The SatLabs Test Setup interface is described in section 8.3-Test System Interface Specifications. In case a specific IFL is not compatible with the test set-up interface, the terminal vendor is obliged to offer a test set-up converter unit offering a test interface compliant to the Test System interface.

### 3 References

- [1] ETSI EN 301 790 v.1.4.1, "Digital Video Broadcasting (DVB); Interaction channel for satellite distribution systems" (2005-09)
- [2] ETSI TR 101 790 v1.3.1, "Digital Video Broadcasting (DVB); Interaction channel for Satellite Distribution Systems; Guidelines for the use of EN 301 790" (2006-09)
- [3] SatLabs Terminal certification Test Plan (Version 6.0: reference sl\_573)
- [4] ETSI TR 101 984 v1.1.1 "Satellite Earth Stations and Systems (SES); Broadband satellite multimedia; Services and Architectures" (2002-11)
- [5] SatLabs System Recommendations: QoS specifications
- [6] SatLabs Interoperable PEP (I-PEP) v1 - Transport Extension and Session Framework for Satellite Communications: Air Interface Specification (2005-10)
- [7] IETF RFC 4291, "IP Version 6 Addressing Architecture" (2006-02)
- [8] ETSI EN 300 468 v1.7.1, "Digital Video Broadcasting (DVB); Specification for Service Information (SI) in DVB systems" (2006-05)
- [9] ETSI EN 302 307 v1.1.2: "Digital Video Broadcasting (DVB); Second generation framing structure, channel coding and modulation systems for Broadcasting, Interactive Services, News Gathering and other broadband satellite applications" (2006-06)
- [10] ETSI TR 102 376 v1.1.1: "Digital Video Broadcasting (DVB); User guidelines for the second generation system for Broadcasting, Interactive Services, News Gathering and other broadband satellite applications (DVB-S2)" (2005-02)
- [11] ETSI TS 102 606 v1.1.1: "Digital Video Broadcasting (DVB); Generic Stream Encapsulation (GSE) Protocol" (2007-10)

## 4 Definitions, symbols and abbreviations

### 4.1 Definitions

#### 4.1.1 Compliance

The general definition of compliance is as follows:

*“Conformance/Compliance is exclusively considered in relation to a specific requirement or requirements document (e.g. specification, standard, guideline). Conformance/Compliance is the fact that a system or component meets the requirement(s) of a specification, standard or similar document.*

*Conformance/Compliance testing is the process of verifying that an implementation performs in accordance with a particular standard or specification. Conformance testing is exclusively concerned with the external behaviour of an implementation. Service and functional behaviour is tested in order to find logical errors and with this to ensure the prerequisites for interoperability.*

*Conformance/Compliance testing is not intended to be exhaustive, and a successfully passed test suite does not imply a 100-percent guarantee. But it does ensure, with a reasonable degree of confidence, that the implementation is consistent with its specification, and it does increase the probability that implementations will interwork.”*

Based on the general definitions above, the SatLabs definition of DVB-RCS compliance is:

***Compliance to Version 1.2 guarantees that a terminal can logon to the DVB-RCS network, maintain its synchronisation, make capacity requests as well as use the corresponding capacity allocations. Compliance also covers IP encapsulation, on both forward and return links, which means that the transport of IP datagrams to and from terminals is enabled.***

***Compliance to Version 1.3 further covers Quality of Service support. DVB-S2 related profiles are also supported. Optionally it also covers iPEP.***

#### 4.1.2 Interoperability

SatLabs terminal interoperability is defined as the ability to operate terminals from different vendors in the same DVB-RCS network.

### 4.1.3 Certification

Certification is defined as the procedure of documenting compliance to regulatory requirements. These tests are outside the scope of this document.

### 4.1.4 Qualification

Qualification is defined as the procedure of documenting compliance to non-regulatory requirements such as the SatLabs System Recommendations given in this document.

### 4.1.5 Services outside the scope

Examples of issues that are outside the scope of the present SatLabs System Recommendations:

- NAT (Network Address Translation)
- Security, encryption
  - Firewall
  - IPsec
  - VPN
  - Forward Link conditional access
- Authentication

Future versions may include recommendations for some or all of these issues or new issues may be added.

### 4.1.6 SatLabs Terminal Profiles

A SatLabs Terminal Profile is a selection of RCS options and parameter ranges that a specific type of terminal shall support. The terminal profiles determine the verification and compliance test cases that are applicable for the SatLabs qualification tests for that profile.

In Version 1.3, two RCST profiles are defined regarding Forward Link standard support:

- DVBS profile (DVB-S support)
- DVBS2 profile (DVB-S2 support)

Both profiles can be supported by a same terminal.

In Version 1.3, terminals supporting DVBS2 profile will also support one of the following DVB-S2 related profiles:

- CCM profile (CCM support)
- ACM profile (CCM, VCM and ACM support)

### 4.1.7 General definitions

For the purposes of the present document, the following terms and definitions apply:

Test System	The test set-up to be used for the SatLabs terminal qualification testing
May, Can	Used to define or describe optional requirements or flexible implementation
Should, Will	Used to define or describe guidelines or preferred implementation
Shall	Used to define or describe mandatory requirements
Recommended	Description of functionality that is recommended to be implemented, but that is either outside the scope of the SatLabs qualification program or describes functionality that is not tested in the SatLabs qualification tests.

## 4.2 Abbreviations

For the purposes of the present document, the following abbreviations apply:

8PSK	8-ary Phase Shift Keying
16APSK	16-ary Amplitude and Phase Shift Keying
32APSK	32-ary Amplitude and Phase Shift Keying
ACM	Adaptive Coding and Modulation
ACQ	Acquisition burst
ARP	Address Resolution Protocol
ATM	Asynchronous Transfer Mode
AVBDC	Absolute Volume Based Dynamic Capacity
BSM	Broadband Satellite Multimedia
BUC	Block Upconverter
CCM	Constant Coding and Modulation
CMT	Correction Message Table
CRA	Continuous Rate Assignment
CRC	Cyclic Redundancy Check
CSC	Common Signalling Channel
CTB	Common Test Bed for DVB-RCS Terminals
DC	Direct Current
DHCP	Dynamic Host Configuration Protocol
DNS	Domain name Server
DULM	Data Unit Labelling method
DVB	Digital Video Broadcast
DVB-S	Digital Video Broadcast via Satellite as specified in EN 300 421
DVB-S2	Digital Video Broadcast via Satellite, 2 <sup>nd</sup> Generation, as specified in EN 302 307
EN	European Norm
FCT	Frame Composition Table
FEC	Forward Error Correction
FTP	File Transfer Protocol
GPS	Global Positioning System
GS	Generic Stream
GSE	Generic Stream Encapsulation
HTTP	HyperText Transfer Protocol
ICMP	Internet Control Message Protocol
ID	Identity
IDU	Indoor Unit
IETF	Internet Engineering task Force
IF	Intermediate Frequency
IFL	Interfacility link
IGMP	Internet Group Management Protocol
INT	IP MAC Notification Table
IP	Internet Protocol
iPEP	interoperable Performance Enhancement Proxy

LAN	Local Area Network
LNB	Low Noise Block
M&C	Management and Control
MAC	Medium Access Control
MF-TDMA	Multi Frequency Time Division Multiple Access
MIB	Management Information Base
MMT	Multicast PID Mapping Table
MPEG	Motion Pictures Expert Group
NAT	Network Address Translation
NCC	Network Control Centre
NCR	Network Clock Reference
NIT	Network Information Table
NLID	Network Layer Information Descriptor
ODU	Outdoor Unit
PAT	Program Association Table
PEP	Performance Enhancement Proxy
PCR	Program Clock Reference
PID	Packet Identifier
PMT	Program Map Table
QoS	Quality of Service
QPSK	Quadrature Phase Shift Keying
RBDC	Rate-Based Dynamic Capacity
RCS	Return Channel via Satellite
RCST	Return Channel via Satellite Terminal
RFC	Request For Comments
RMT	RCS Map Table
RSAT	Regenerative SATellite terminal
Rx	Reception
SAC	Satellite Access Control
SCT	Superframe Composition Table
SI	Service Information
SNMP	Simple Network Management Protocol
SPT	Satellite Position Table
SSR	SatLabs System Recommendations
STP	SatLabs Terminal Profile
SYNC	Synchronization
S/W	SoftWare
TBTP	Terminal Burst Time Plan
TCT	Time-slot Composition table
TDMA	Time Division Multiple Access
TFTP	Trivial File Transfer Protocol
TIM	Terminal Information Message
TMST	Transmission Mode Support Table
TRF	Traffic
TS	Transport Stream
Tx	Transmission
VBDC	Volume-Based Dynamic Capacity
VCM	Variable Coding and Modulation
VPN	Virtual Private Network

## 5 Reference architecture

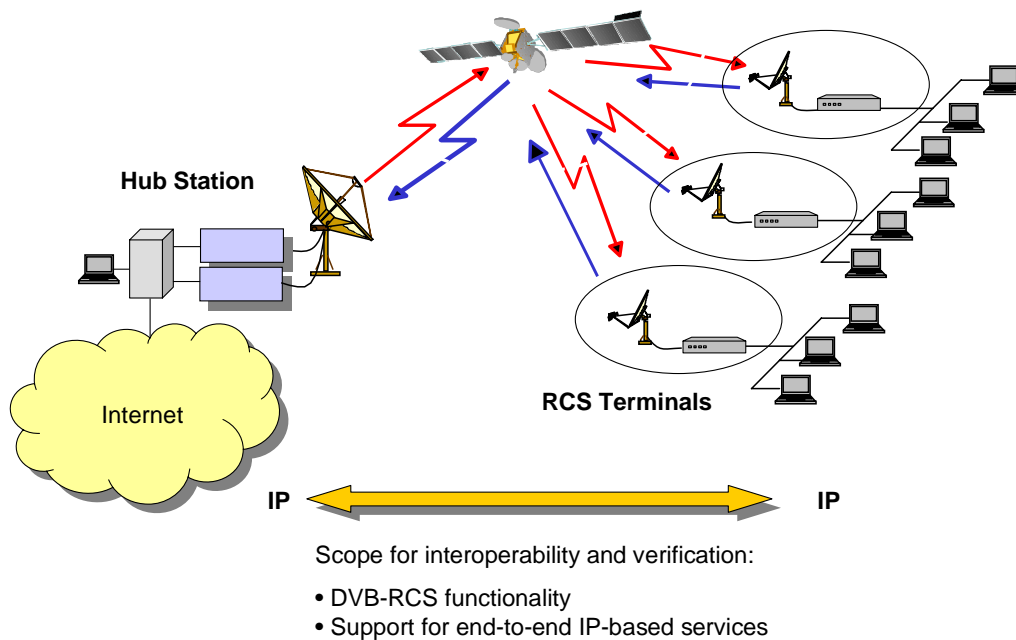

Figure 5-1: RCST network supporting basic IP services with interfaces labeled according to [5]

### 5.1 Baseline DVB-RCS network

Figure 5.1 RCS network supporting basic IP services with interfaces labeled according to [5].

The interfaces in the figure above are labelled according to the reference model defined by [5], ETSI in TR 101 984 Broadband Satellite Multimedia (BSM); Services and Architectures. The interfaces are defined as follows:

- **I.2** is the BSM Network Interface; the interface between the satellite access function and the customer premises networks
- **I.5** is the Air Interface on the RCST side
- **I.6** is the Air Interface on the gateway side
- **I.10** is the BSM Gateway Interface; the interface between the satellite gateway function and terrestrial core networks.

## 5.2 Terminal architecture

The terminal architecture is defined in Figure 10.1 in [2], dividing the terminal into an outdoor unit (ODU) and an indoor unit (IDU) connected by an InterFacility Link (IFL). A simplified diagram of the terminal is shown in Figure 5.2.

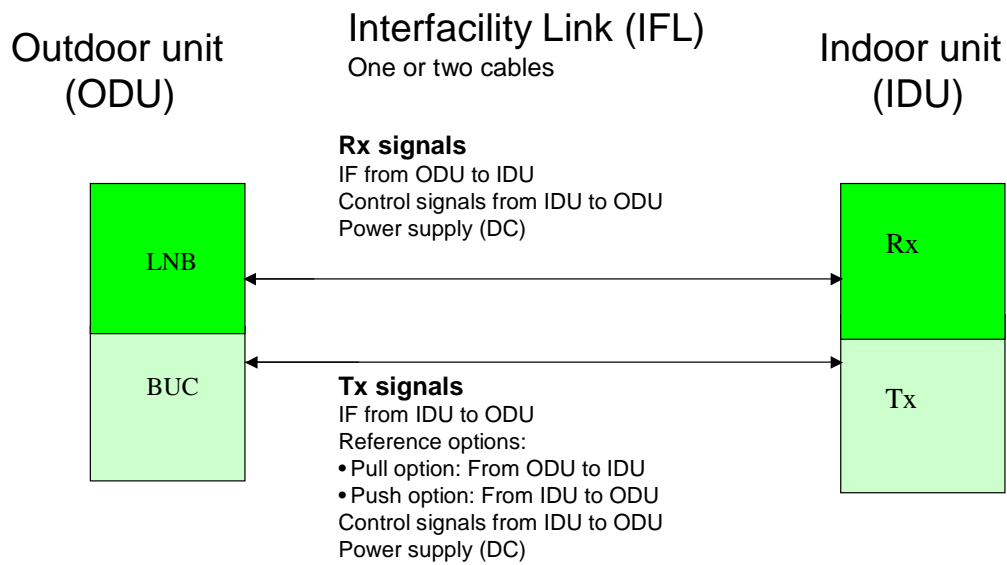

Figure 5-2: RCS terminal Interfacility Link

### Push concept

The frequency reference is present in the indoor unit and supplied to the outdoor unit upconverter via the transmit RF cable.

### Pull concept

The frequency reference is present in the outdoor unit and supplied to the indoor unit via the transmit RF cable.

## 6 Technical Recommendations

### 6.1 Introduction

When comparing the SSR with [1] and [2], the SSR provides inputs in the following main categories:

- Specifications and implementation guidelines for additional functionality to ensure the goal of interoperable RCS terminals supporting a defined set of basic IP services. These issues are addressed in section 6.2 - Basic IP service recommendations
- Identification of RCS specifications that are not within the current scope of the SatLabs System Recommendations, addressed in section 6.3 - DVB-RCS specifications outside current scope.
- Clarification of specifications for functions that may cause interoperability problems as they are originally defined in [1] and [2]:
  - Capacity request handling and QoS management
  - Frame and super-frame definitions
  - Timing and synchronization

These issues are discussed further in section 6.4 - DVB-RCS interoperability recommendations.

Grouping of DVB-RCS specified mandatory and optional functions defining SatLabs terminal profiles. This is addressed in section 0 -

- Terminal Options and Parameter Rangesanges.
- Selection of DVB-RCS specified parameters to establish verification test cases to be used for SatLabs qualification testing and as proven interoperable RCS terminal configurations, addressed in section 8 - Qualification Testing.

The following sections define terminal functionality and DVB-RCS clarifications and enhancements to be applied for SatLabs compliant terminals. The implementation of optional features and features outside the scope of the SatLabs recommendations shall not interfere with the functionality within the scope of these Recommendations. It is a requirement that such functionality shall enhance the terminals capabilities and complement the SatLabs specified functionality. It is therefore a requirement that if such options are offered on a SatLabs certified terminal, these options shall be enabled under the qualification tests, ensuring that the availability of the function itself does not interfere with the SatLabs specified functional requirements. However, some terminal features may be disabled under tests as specified in the test cases to enable an efficient and practical test environment.

## 6.2 Basic IP service recommendations

### 6.2.1 IP services

The goal for RCS terminal interoperability at the application level is to enable support of basic IP services. Basic IP services are defined as the ability to support forwarding of IP packets using protocols such as HTTP, Telnet, FTP and SNMP.

The RCS terminal shall comply with the relevant sections of the specifications listed in Table 6-1.

Protocol	Specification reference, comment
Basic Internet Protocol (IP) support	As described in RFC 791
ICMP	As described in RFC 792 Congestion control is not to be supported
IP routing (ARP)	As described in RFC 1812 ARP on local port only
IP DiffServ	As described in RFC 2474, 2475, 2597 and 3246. See [5].
SNMP	As described in RFC 3416.
TFTP	As described in RFC 1350.

Table 6-1: Basic IP functionality to be supported by SatLabs compliant terminals

### 6.2.2 Multicast

Multicasting is an inherent strength of satellite communications and is an important application of the RCS terminals. The support of forward link multicast services in RCS systems is described in section I.6 in [2], where the use of the Multicast PID Mapping Table (MMT) is assumed. ETSI has recently released an updated version of EN 301 192 (v.1.3.1, 2003-01) describing the use of INT (IP MAC Notification Table) for multicast signalling.

Version 1.3 Terminals can support multicast and the MMT as an option (MMT option).

### 6.2.3 Enhanced Quality of Service support

The present SSR includes specifications for enhanced QoS support, described in [5]. The support of Expedited Forwarding (EF) and Assured Forwarding (AF) Per Hop Behaviors (PHB) is part of the ENHQOS option.

## 6.2.4 Interoperable Performance Enhancement Proxy support

As part of the PEP option, compliant terminals shall follow the specification for interoperable Performance Enhancement Proxy (iPEP) support, described in [6].

## 6.2.5 HTTP pre-fetching support

As part of the HTTP option, compliant terminals shall follow the specification for HTTP single-side pull pre-fetching, as described in the following.

The basic idea with HTTP Pre-fetching is to anticipate the browser requests for embedded Web objects. These objects are fetched, ahead of time, from the server and made available on the client side for immediate or future retrieval by the client browser.

The basic steps involved in the HTTP Pre-fetching mechanism are as follows:

- Interception of the HTTP Get response to a requested Web page on one of the intermediate HTTP Pre-fetching proxy devices.
- Parsing of the HTML content of the HTTP Get response in order to identify and select the embedded Web objects to be pre-fetched.
- Pre-fetching of the selected embedded Web objects from their respective server(s).
- Parallel transfer of the pre-fetched embedded Web objects across the satellite link.
- Caching of the pre-fetched embedded Web objects on the client side HTTP Pre-fetching proxy device.
- Servicing of client HTTP requests for pre-fetched embedded Web objects from the cache of the client side HTTP Pre-fetching proxy device.

In the pull model, the transfer of pre-fetched embedded objects is initiated from the client side once the HTTP Get response has been intercepted and parsed.

In the single side pull approach, a single HTTP Pre-fetching device is used on the client side as illustrated in the figure below.

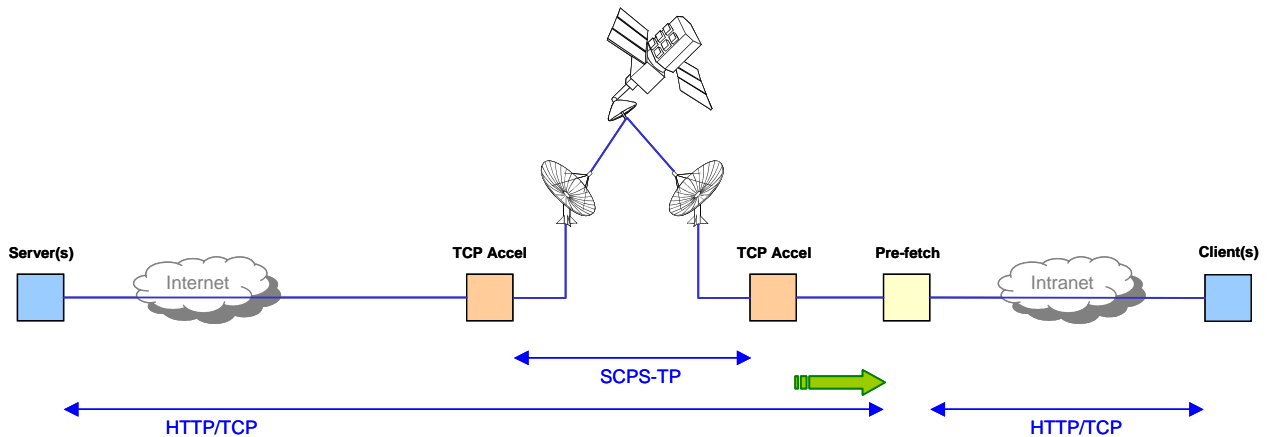

Figure 6-1: Single Side Pull Architecture

The HTTP Pre-fetching device pre-fetches/pulls the embedded Web objects directly from the server(s).

In the example illustrated below, the client browser uses two parallel connections as usual. The HTTP Pre-fetching device on the client side intercepts the response to the requested Web page and immediately starts to pre-fetch its four embedded Web objects using four parallel connections.

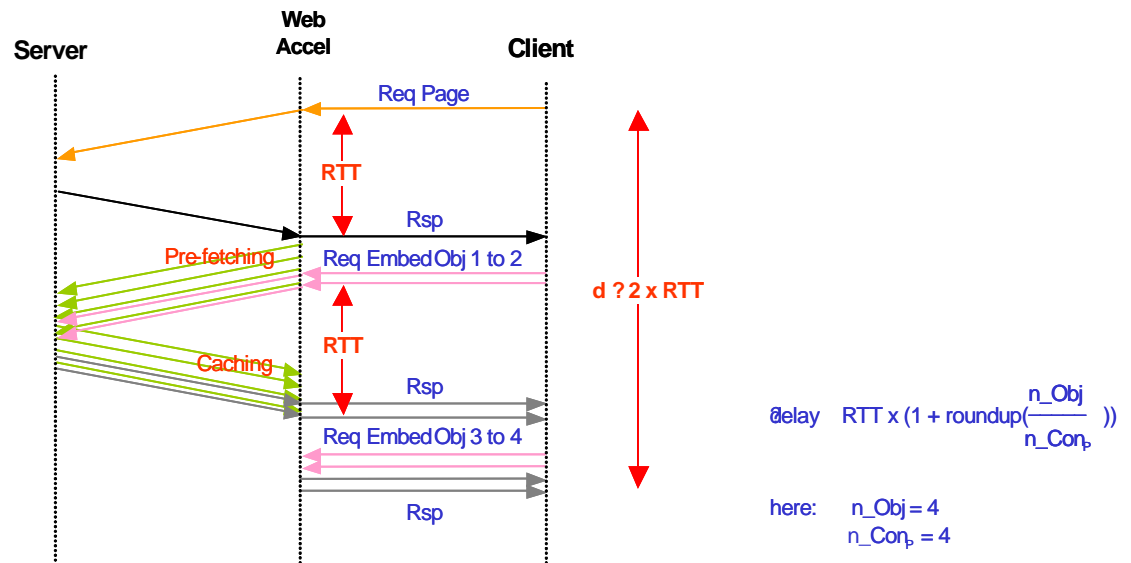

Figure 6-2: Single Side Pull Example

The time to transfer each individual Web object is considered negligible. Also, the use of non persistent HTTP 1.0 connections is assumed and we are still relying on PEPs to bypass the TCP three-way handshake.

The pre-fetched objects are cached on the client HTTP Pre-fetching device but no client request delaying is performed. Therefore, when the client browser requests the first two embedded objects, these objects are not yet available in the cache of the client HTTP Pre-fetching device and the requests are simply forwarded to the target server. After receiving the first two embedded objects from the server, the browser will then request the next two embedded objects which can now be served from the cache of the client HTTP Pre-fetching device thereby avoiding an additional satellite RTT.

## **6.3 DVB-RCS specifications outside current scope**

### **6.3.1 General**

The RCS specifications cover a number of options and describe optional functionality that may prevent interoperability of RCS terminals if terminals implement different options. The goals of these Recommendations are to focus on the operational aspects ensuring basic interoperability for the basic IP service. Issues that are left outside the scope of these Recommendations are:

- DULM functionality
- Power control implementation guidelines
- RSAT issues

Unless specifically commented in these Recommendations, the DVB-RCS Specifications [1] apply.

### **6.3.2 SNMP**

In [1], SNMP is specified as an optional mechanism for RCST configuration, management and control. An optional MIB is also provided. These issues are outside the scope of the SatLabs System Recommendations v1.3, and SNMP remains an optional mechanism that currently will not be subject to SatLabs qualification testing in v1.3.

## 6.4 DVB-RCS interoperability recommendations

### 6.4.1 Introduction

This section specifies mandatory and optional DVB-RCS related functionality for SatLabs compliant terminals. The first section describes mandatory mechanisms for network control and terminal configuration. The remaining sections clarify parts of the standard that are either ambiguous or allow implementations that are not interoperable.

### 6.4.2 Network Control

#### 6.4.2.1 Introduction

Interoperable mechanisms providing basic network control functions are essential for operating and managing networks. This section defines the mandatory control functions and mechanisms for providing basic network configuration and control functions in compliance with [1]. The mechanism categories are divided into:

- Forward link signalling to the terminal using RCS tables as defined in [1]
- Local control of terminal parameters and settings

#### 6.4.2.2 Forward link signalling

RCS tables and descriptors will be used in the SatLabs Qualification tests forward link stream as described in Table 6-2:

Table	Qualification Testing Descriptors	Comments
NIT	Linkage Satellite Delivery	Standard DVB table
PAT		Standard DVB table
PMT	RCS Content	Standard DVB table
NCR	Optional payload	
RMT	Linkage (private data) Satellite Forward Link Satellite Return Link	
SCT		
FCT		
TCT		
SPT		The position of a geostationary satellite will be signalled in the SPT table. The test bed will compensate for the expected delay compensation provided by the terminal.
CMT		

Table	Qualification Testing Descriptors	Comments
TBTP		The RCST is expected to handle TBTP tables for time slot allocation in the range between 90 ms and 1 second in advance of the current network time.
TIM-U	Correction Message Forward Interaction Path Logon Initialize SYNC Assign ACQ Assign (Coarse sync. option) Return Interaction Path Satellite Return link descriptor	Present for COARSE_SYNC option only Mandatory for ENHQOS option support. Format defined in 6.4.2.3.
TIM-B	Contention Control Correction Control	The Superframe ID shall match the Superframe ID found in the RMT.
MMT	Multicast PID Mapping Table	Optional (MMT option) for Version 1.3.
TMST		For DVBS2 profile only.

Table 6-2: Forward Link signalling

### 6.4.2.3 Return Interaction Path Descriptor

RIP descriptor is used to define multiple logical return link path (VPI/VCI, PID, Channel\_ID, Route\_ID). It is mandatory as part of the ENHQOS option support.

Efforts have been made while defining how tables and descriptors fields are coded in the DVB-RCS standard; all 8-bit, 16-bit, 24-bit or 32-bit fields are aligned at least on an 8-bit address.

A divergence to that rationale was introduced in the Return Interaction path Descriptor coding. The placement of the "VPI/VCI\_flag", "Route\_ID\_flag" and the "Channel\_ID" fields prevents a smooth alignment of their succeeding fields. It is assumed that the lack of octet alignment in the currently specified RIP format is highly undesirable.

SatLabs therefore mandates the RIP format as defined in Table 6-3.

The proposed RIP format is not compatible with RIP as specified in [1]. However, it is assumed that current implementations of RIP use the format proposed here below. The incompatibility is thus believed to not constitute any problem.

Syntax	No. of bits		Information Mnemonic
	Reserved	Information	
Return_interaction_path_descriptor() {			
descriptor_tag		8	uimsbf
descriptor_length		8	uimsbf
Network_Routing_Label_loop_Count	4	4	uimsbf
For (i=0; i<= Network_routing_Label_loop_Count; i++) {			
Allocation_Desallocation_flag	6	1	blsbf
PID_flag		1	blsbf
If (PID_flag == 1) {			
PID_loop_count		8	uimsbf
For (j=0;			
j<= PID_loop_Count; j++) {			
PID	3	13	uimsbf
}			
}			
VPI/VCI_flag	7	1	blsbf
If (VPI/VCI_flag == 1) {			
VPI/VCI_loop_count		8	uimsbf
For (k=0; k<= VPI/VCI_loop_Count; k++) {			
VPI		8	uimsbf
VCI		16	uimsbf
}			
}			
Route_ID_flag	7	1	blsbf
If (Route_ID_flag == 1) {			
Route_ID_loop_count		8	uimsbf
For (l=0; l<= Route_ID_loop_Count; l++) {			
Route_ID		16	uimsbf
}			
}			
Channel_ID	4	4	uimsbf
}			
}			
NOTE:	*Reserved bits are of type blsbf, and shall precede the Information bits on the same line. They shall be ignored by the RCST. For an encrypted unicast TIM, the bit values shall be varied in a random manner to avoid encryption spoofing.		

Table 6-3: Return Interaction Path descriptor format

#### 6.4.2.4 TIM RCST status bits

The unicast TIM RCST status bit fields are defined in [1]. For SatLabs qualification testing the comments listed in Table 6-4 apply:

Field name	Comments
ID_encrypt	Not tested
Logon_fail_(busy)	Tested
Logon_denied	Tested
Log_off	Tested. See comment below.
Transmit_Disable	Tested
Rain_Fade_release	Not tested.
Rain_Fade_detect	Not tested
Wake_up	Tested.

Table 6-4: TIM RCST status bits

#### 6.4.2.5 Behaviour of RCST after reception of log-off in RCST status field

A terminal shall log-off the network after the reception of a unicast TIM with log-off in the status field. It is not defined in [1] how the terminal shall behave to try to re-enter the network, i.e. how soon and how many times CSC messages can be retransmitted. The RCS terminal behaviour in this situation is outside the current scope of the SatLabs System Recommendations. However, manufacturers should take care that different implementations on this issue should not lead to any operational interoperability problems.

#### 6.4.2.6 CSC burst contents

A common understanding of the terminal capabilities signalled in the CSC burst as defined in [1] is critical for ensuring interoperability. For SatLabs qualification testing the following comments listed in Table 6-5 apply:

Field name	Comments
Security	Not tested
SNMP	Not tested
ATM connectivity	Not tested
MPEG2-TS TRF	Optional tests (MPEG_TRF option)
RCST boards	One board assumed, other configurations not tested
RCST ACQ	For SatLabs compliant terminals this field is defined to signal the capability of the terminal to support the Coarse Sync procedure and optionally to transmit ACQ bursts if instructed to do so by the Hub. If this field is not set, it is assumed that the Hub will not assign ACQ bursts to the terminal by not including the ACQ_Assign descriptor in the TIM-U logon message. If this field is set, the Hub may choose to assign ACQ bursts to the terminal in the TIM-U logon message. If the Hub does not assign ACQ bursts, but only a SYNC burst, the terminal shall respond by sending a SYNC burst in the assigned slot. The terminal shall automatically adapt to the TIM-U signalling contents on the fly without changing any configuration parameter of the terminal. It is recommended that terminals not supporting ACQ handle reception of the ACQ_assign_descriptor by ignoring the descriptor contents
Multi_IDU	Not tested, single IDU assumed in test setup
S/W version	Not tested

Field name	Comments
Freq Hopping Range	20 MHz hopping range tested. 120 MHz is tested as an option (WIDE_HOPP option).
MF-TDMA	Optional tests (Dynamic_MF_TDMA option)
RCST Class	Not tested
Route_ID capable	Optional test (ROUTE_ID option)
RCST Mode	Operational Mode assumed, other modes not tested.
RCST MAC address	Tested
CSC_Route_ID	Not tested
Dynamic connectivity	Not tested. The use of this bit is not described in [1] or [2].
Frequency Hopping	Tested. Fast frequency hopping is tested as an option (FAST_HOPP).
DVB-S capability	For DVBS profile, value shall be '1'. For DVBS2 profile, if DVBS profile is not supported, value shall be '0'.
DVB-S2 capability	In [1], DVB-S2 capability field is defined for RCST which are capable of using DVB-S2 for forward link reception. For SatLabs qualification testing, the following values apply: <ul style="list-style-type: none"> <li>- '11' for not DVB-S2 capable (DVBS profile supported, DVBS2 profile not supported)</li> <li>- '01' for DVB-S2 capable of using CCM only (DVBS2 profile supported, CCM profile supported, ACM profile not supported)</li> <li>- '00' for DVB-S2 capable of both ACM and CCM (DVBS2 profile supported, ACM profile supported)</li> </ul>
Burst type Identifier	Tested

Table 6-5: CSC burst content

### 6.4.2.7 Configurable terminal parameters

The following DVB-RCS parameters shall be configurable with a documented user interface:

- Start-up carrier frequency
- Start-up forward link code rate (unless this is automatically detected)
- Start-up forward link symbol rate
- Start-up ISI (when MULTITS option is supported)
- Network ID
- Population ID
- QoS related parameters, as described in [5].

In addition information about how to setup the terminal to pass IP traffic through the terminal must be supplied.

Examples of configuration tools are:

- SNMP
- web browser interface
- local control interface such as CLI (Command Line Interface)

If special software tools are needed to configure the terminal, such tools shall be supplied by the terminal manufacturer.

#### **6.4.2.8 ACQ and SYNC Reply Timeout**

It is recommended that the ACQ and SYNC burst time-outs are set shorter or equal to the repeat period. This is implemented by ensuring that the parameter SYNC\_reply\_timeout and ACQ\_reply\_timeout is not larger than the SYNC\_repeat\_period and the ACQ\_repeat\_period in the forward link signalling.

#### **6.4.2.9 SYNC burst contents**

For the purpose of SatLabs qualification testing, all SYNC bursts include a SAC field and a CRC.

### **6.4.3 SAC**

#### **6.4.3.1 SAC field length**

The maximum SAC length is defined in [1] to be up to 31 bytes long. For the purpose of SatLabs qualification testing, the following SAC lengths shall be used:

- 4 bytes when used as prefix to ATM TRF bursts.
- 14 bytes (excluding CRC) for Turbo encoded SYNC bursts

#### **6.4.3.2 Channel ID**

The Channel ID shall be used for supporting QoS functionality as specified in the QoS specifications [5].

#### **6.4.3.3 Fine Sync Achieved message**

After reaching the Fine Sync state, it is recommended that the terminal continues to send SAC messages with the Fine\_sync\_achieved flag set until a CMT for this message is received from the hub, confirming that the hub has received this information. The terminal may choose to send SAC messages at any time with this flag set as long as the terminal is in the Fine Sync state.

### **6.4.4 Terminal capacity requests**

#### **6.4.4.1 General**

The terminal shall support RBDC, VBDC and AVBDC capacity request categories. The use of the capacity request classes is specified in the QoS specifications [5].

#### **6.4.4.2 RBDC**

This section is obsolete and replaced by specifications in [5].

## 6.4.5 Return Link Variability

The RCS tables sent on the forward link contain all the parameters required to build the return link frame and bursts. When an RCST boots, it will acquire an initial set of tables and configure the modem appropriately. An RCST may also have a default framing structure that can be overwritten by the forward link tables. However, the way in which an RCST reacts to changes in this initial set of tables is not defined in [1] or [2].

There are several operational reasons why a system configuration would change:

- Capacity changes – the system bandwidth is increased or decreased.
- System Reconfiguration – to react to traffic patterns or other operational issues
- Load Balancing – carrier symbol rates could be changed based on the terminal distribution

The Hub may force the terminal to log off before system reconfiguration.

The RCST may react to changes in the forward signalling tables by:

### 1. *Reboot*

The RCST tracks the return link composition. Any changes to this composition cause the RCST to automatically reboot.

### 2. *Re-initialisation*

The RCST logs off and re-acquires all tables when a change is discovered.

### 3. *Reconfiguration On-the-Fly*

The RCST is able to process the changes on the fly and react in a timely fashion to changes in return link configuration.

The reboot mechanism can have major system implications. Terminals that all react simultaneously by rebooting can attempt to re-login simultaneously. This may fail based on the number of available CSC slots. If the operator assigns more CSC slots to handle the re-logons and then removes them, the change will be noticed and the cycle begins again.

It is therefore a requirement for SatLabs compliance that RCSTs have the ability to handle changes in the number of CSC slots on-the-fly without changing the terminal state.

The terminal may have the capability of handling signalling changes on-the-fly without the need for rebooting. To simplify the interoperability testing, the SatLabs qualification testing will be performed assuming that a reboot is necessary to activate new configurations, with the exception of CSC slot reconfiguration as described in the paragraph above.

### 6.4.6 Turbo code permutation (New permutations)

It is a mandatory requirement in [1] that terminals are capable of updating Turbo code permutation parameters signalled via the TCT as described in clause 8.5.5.4 in [1] in addition to supporting the default parameters defined in table 5 of section 6.4.4.1 in [1]. This feature is defined as outside the scope for the SatLabs System Recommendations and will not be tested in the qualification program.

### 6.4.7 Time to remain in non-operational states

It is not defined in [1] how long the RCST shall remain in the Off/Stand-by state after:

- receiving a unicast TIM with “Logon\_denied”
- receiving a unicast TIM with “Logon\_fail\_(busy)”
- unsuccessful Coarse Sync procedure
- unsuccessful Fine Sync procedure
- unsuccessful Sync Maintenance procedure

To ensure consistent qualification testing and operational interoperability, it is required that it is possible to configure the following parameter:

- Wait\_in\_standby\_mode

This parameter shall apply to all the events listed above. Alternatively, parameters that can be configured the same way can be defined for each event.

### 6.4.8 Reference timing

#### 6.4.8.1 NCR Reference Plane

The default NCR reference time plane is defined to be at the satellite used for the return link. The NCR optional payload may offset this time reference as described in the next section.

#### 6.4.8.2 NCR Optional Payload

Implementation of the optional payload field in the PCR Insertion TS packet provides a generic method for the distribution of synchronization information critical to the operation of complex satellite network architectures, comprising multiple forward link and return link satellites and multiple gateways. The method is equally applicable to systems where a single satellite supports both the forward and return links.

The recommendations for using the NCR optional payload are found in Appendix B. The presence of the optional payload shall be signaled in the PMT for RCS tables.

For version 1.3 SatLabs qualification testing, the support of NCR optional payload is mandatory.

### 6.4.8.3 RCST internal delay compensation

A common timing reference for the IDU is essential for terminal interoperability. The definition of the terminal time reference is found in [1], section 6.1.3, 4th paragraph:

*Burst synchronization accuracy shall be within 50 % of a symbol period. The resolution shall be 1 NCR count interval. The burst synchronization accuracy is the worst case deviation of the scheduled start of burst time and the actual start of burst time at the transmitter output. The scheduled start of burst time is the point in time when the ideal reconstructed NCR equals the value written in the TBTP for that burst. The ideal reconstructed NCR is defined as observed at the output of an ideal delay-less DVB-S receiver. Compensation for the receiver delay, if required to achieve the specified accuracy, shall be done by the RCST.*

The same type of NCR reconstruction and burst synchronization is assumed also by a DVB-RCS terminal applying an ideal DVB-S2 receiver.

The ideal delay-less DVB-S receiver is, in addition to compensate for its own receiver delay, defined to compensate for the full delay in the convolutional interleaver corresponding to the transmission time for 11 MPEG-TS stream packets at the operating forward link coding and symbol-rate, taking the Reed-Solomon coding into account.

The NCR value of a DVB-S2 ACM/VCM signal is associated to the occurrence of the first symbol of the SOF field for the (n-2)th PL frame when the n'th PL frame contains the most significant bit of the specific NCR value, ref. section 6.1.1 of [1] and Annex G.5 of [9]. The ideal delay-less DVB-S2 ACM/VCM receiver is defined to reconstruct the NCR according to this reference.

The ideal delay-less DVB-S2 CCM receiver is defined to compensate for its own receiver delay. This includes compensation for any delay through the de-interleaving and any delay through the FEC decoder. The definition is applicable when using a single transport stream over DVB-S2 CCM.

The maximum allowed error in the timing reference over the DVB-S/S2 forward link and DVB-RCS return link parameter range is defined in Table 6-6.

Forward Link rate	Allowed deviation*
< 2 Msps	21 microseconds + 1 return link symbol (TBC in CCM mode)
2-10 Msps	13 microseconds + 1 return link symbol (TBC in CCM mode)
> 10 Msps	6 microseconds + 1 return link symbol (TBC in CCM mode)

\*Includes test bed measurement uncertainty of 4 microseconds.

Table 6-6: Allowed deviation in the timing of the CSC burst transmission

*Note: It is recognized that it is difficult to fetch an accurate NCR reference point from the IF signal. Calibration of the internal delay compensation is thus offered as a service as an initial part of the qualification test. The terminal vendor must then provide the necessary means so the delay compensation applied by the terminal can be calibrated. The calibration is performed at one of following link configurations, as applicable for the given terminal:*

*Forward Link Type, one of the following:*

*DVB-S*

*DVB-S2-QPSK-LongFrame-NoPilot-SingleTS*

*DVB-S2-QPSK-ShortFrame-NoPilot-SingleTS*

*Forward link rate: 8.888 Msps, 2/3 coding rate*

*Return link CSC slot carrier: 512 kbps, 1/2 rate turbo coding*

*The terminal vendor must assure that all other configurations apply the same timing as the configuration used for calibration. The correct compensation value must be inserted in the terminal as a non-volatile parameter before commencing with the qualification testing.*

#### 6.4.8.4 SPT table contents in the Qualification testing Test bed

For SatLabs qualification testing, SPT tables signalling the position of geostationary orbit satellites shall be used. The test setup will compensate for the lack of propagation delay between the terminal and test bed.

#### 6.4.8.5 Superframe start time signalled in SCT

The superframe start time in the SCT shall be within a range corresponding to no more than plus or minus 32767 superframe durations of the current NCR value.

#### 6.4.9 DSM-CC Encapsulation and Section Packing

#### **6.4.9.1 Encapsulation**

According to the DVB standards, the maximum DSM-CC section size for data transport is 4096 bytes, while for the SI tables the maximum length is 1024 bytes. Only one IP packet shall be encapsulated in a DSM-CC section. For SatLabs compliance the RCST shall as a minimum support transport of 1500 MTU Ethernet frames in a single DSM-CC section. This is also the maximum payload size that is used in the certification testing.

#### **6.4.9.2 Section packing**

Section packing allows for multiple DSM-CC sections to be packed in a single MPEG packet. This entails the termination of one DSM-CC section followed immediately by the start of a second DSM-CC section. Alternatively, several short DSM-CC sections may be accommodated within a single MPEG packet (for example: 1 section terminates, 1 complete section, the start of another section).

Section packing is defined in ISO/IEC 13818-1 Appendix C.3 and allows a new DSM-CC section to start at an arbitrary position in the transport stream packet thanks to the pointer field that indicates the start of the first DSM-CC section starting in the current transport stream packet.

Section packing support on the forward link is a mandatory feature for SatLabs v1.3 compliant terminals.

On the return link the terminals that support the MPEG\_TRF option shall support section packing. For these terminals, the hub is assumed to support section packing for MPEG TS packets on the return link.

#### **6.4.10 Slow Hopping**

A terminal supporting only Slow Hopping shall not transmit in assigned time slots for which a stable frequency can not be achieved.

#### **6.4.11 Return Link Code Rates**

The code rates  $1/3$  and  $2/5$  have been found to mainly be applicable for CSC and SYNC slots. The SatLabs qualification testing will therefore not be performed for Traffic bursts at the code rates  $1/3$  and  $2/5$ .

#### **6.4.12 Return Link Symbol Rate Granularity**

The granularity of the return link symbol rate shall be 1 symbol per second. In the SatLabs qualification testing, the symbol rates will be selected at random with a granularity of 1 symbol per second.

#### **6.4.13 Superframe Duration Range**

The superframe duration test range is limited to between 25 and 750 milliseconds for the SatLabs qualification testing.

#### **6.4.14 Fixed MF-TDMA**

With reference to [1], Clause 6.7.1.1, the following interpretation shall be used for fixed MF-TDMA functionality:

In fixed MF-TDMA systems all TRF slots which are allocated to a Fixed MF-TDMA terminal must be equal with respect to the `symbol_rate`, the `inner_code_type`, the `inner_code_ordering`, the `outer_coding`, the `inner_code_puncturing`, the modulation and the `baseband_shaping`. Furthermore, SYNC bursts must be equal with the allocated TRF slots with respect to the `symbol_rate`. Other parameters defining a burst might differ between SYNC and TRF slots. The `inner_code_type`, `inner_code_ordering`, modulation and `baseband_shaping` are equal for all bursts.

#### **6.4.15 Handling of unexpected signalling information**

The terminal shall ignore information that is not understood or not valid. For valid packets that are received out of order, such as receiving an unexpected CMT table, the terminal may choose to apply the signaled information, such as correction data.

#### **6.4.16 Handling of the scaling factor related to timing corrections**

It is recommended that terminal complies with the use of the scaling factor for doing timing correction as described in the following sections.

##### **6.4.16.1 Common scaling for Correction Message and SYNC/ACQ Assign Descriptors**

The `burst_time_scaling` value of the Correction Message descriptor shall apply also for the SYNC Assign descriptor and the ACQ Assign Descriptor that occurs in the same unicast TIM. The absolute thresholds for ACQ achieved and SYNC achieved is found by scaling the value of the `ACQ_achieved_time_threshold` and `SYNC_achieved_time_threshold` according to this `burst_time_scaling` value. The scaling shall use the same mid-range value approximation method as when scaling the `burst_time_correction` value.

##### **6.4.16.2 Independent scaling of burst\_time\_correction given in CMT**

The `burst_time_correction` value of a CMT shall be scaled according to the `burst_time_scaling` value related to the same RCST by the same CMT. Thus, the `burst_time_correction` value of the CMT cannot be directly compared with the values of the `ACQ_achieved_time_threshold` and the `SYNC_achieved_time_threshold`. The values have to be scaled according to the respective `burst_time_scaling` values.

##### **6.4.16.3 Adjustment of the SYNC\_achieved\_time\_threshold**

As the `SYNC_achieved_time_threshold` at logon may be given with insufficient precision it can be necessary to update the parameter with a more precise value. An additional TIM with a `SYNC_Assign_Descriptor` and a `Correction_Message_Descriptor` will update the fine synch threshold.

#### **6.4.17 DVB-S2 support**

DVB-S2 is specified in [9] and [10]. DVB-RCS support for DVB-S2 forward link is defined in [1] and [2].

Terminal supporting DVBS2 profile shall also support one of the following DVB-S2 related profiles:

- CCM profile (CCM support)

- ACM profile (CCM, VCM and ACM support)

Details of the features supported by each profile are specified in Table 6-7.

System Configurations	Description	CCM profile	ACM profile
QPSK	1/4, 1/3, 2/5		O
	1/2, 3/5, 2/3, 3/4, 4/5, 5/6, 8/9, 9/10	M	M
8PSK	3/5, 2/3, 3/4, 5/6, 8/9, 9/10	M	M
16APSK	2/3, 3/4, 4/5, 5/6, 8/9, 9/10	O	O
32APSK	3/4, 4/5, 5/6, 8/9, 9/10		O
CCM		M	M
VCM			M
ACM			M
FECFRAME (normal)	64800 (bits)	M	M
FECFRAME (short)	16200 (bits) – no 9/10 support		M
Single Transport Stream		M	M
Multiple Transport Stream			O
Single Generic Stream			
Multiple Generic Stream			
Combined Single Generic & Single TS			O
ISSY (input stream synchronizer)			
Roll-Off	0,20	M	M
With Pilots		M	M
Without pilots		M	M
<b>RCS Specific</b>			
Transmission Mode Support Table			M
ACM sub field support CNI & MODCOD_RQ	in SAC		M

Table 6-7: DVB-S2 options description

In the above table, the following values mean:

- M: Mandatory
- O: Optional
- If no value is given, the corresponding functionality is not tested

Note 1: For the ACM profile, ACM operation will be tested with short frames only and CCM operation will be tested with normal frames only.

For the CCM profile, only CCM operation will be tested, with normal frames.

Generic Stream (GS) alone is currently out of SatLabs certification scope.

Only combined Single GS and single TS is considered and forms the GSTS option (see 7.3). When GSTS is supported, all standard MPEG and DVB signaling shall be transported over the TS. GS shall use the Generic Stream Encapsulation (GSE) defined in [11].

## 6.5 DVB-RCS extensions

### 6.5.1 Introduction

This section specifies mandatory and optional functionality for SatLabs compliant terminals for supporting functionality not specified in [1], and for performing the SatLabs qualification tests.

### 6.5.2 Control of terminal behaviour

For efficient terminal qualification testing it is necessary to be able to control some aspects of the terminal behaviour, such as to explicitly enable and disable the use of capacity request categories. The features that must be configurable are shown in Table 6-8. Only controls for the supported features are required.

Control ID	Name	Comment
Manual_logon	Manual logon command	Used for logon test.
Manual_logoff	Manual logoff command	Used for logoff test.
RCST_position	Terminal position on earth	Configuration parameters
Wait_in_standby_mode	Time to wait in standby mode before trying to re-enter the network	Used for defining terminal behaviour in stand-by mode. The value shall be configurable between 0 and 20 seconds in 1 second steps.
Reboot	Order reboot of the terminal	Used to reset the terminal

Table 6-8: Configurable terminal features for SatLabs testing

The terminal vendor shall provide documentation of how the terminal features in Table 6-8 are controlled to the laboratory performing the qualification testing.

### 6.5.3 Quality of Service

The terminal shall support the QoS functionality specified in [5], except that the HM&C specification is not applicable to the definition of configuration parameters of RCST.

## 7 Terminal Options and Parameter Ranges

### 7.1 Introduction

This section specifies the list of options to be supported by SatLabs terminals. Two categories of options are detailed:

- Options defined in the DVB-RCS standard [1], which support is made mandatory. The associated functionality is to be supported and tested
- Options, as defined by either DVB-RCS or SatLabs that may be supported. The associated functionality is only tested if the Option is declared to be supported.

This section also defines the applicable parameter ranges for interoperability and corresponding qualification testing. The verification and interoperability testing is based on a selection of parameters within the defined ranges. The terminal shall support any parameter setting within the declared parameter range in compliance with the DVB-RCS [1] standard and these SatLabs System Recommendations.

### 7.2 Mandatory DVB-RCS options

The list of mandatory DVB-RCS options that all SatLabs compliant terminals must support are listed in Table 7-1.

Acronym (ID)	Description
ATM_TRF	ATM TRF burst formatting
TURBO	Turbo coding with default permutation parameters
FINE_SYNC	Fine Synchronization
WAKE_UP	RCST supports "wake up" from the Hub
CRC_SYNC	RCST supports SYNC bursts with CRC
VBDC	RCST supports VBDC capacity request class
RBDC	RCST supports RBDC capacity request class
AVBDC	RCST supports AVBDC capacity request class

Table 7-1: DVB-RCS options supported by all SatLabs compliant terminals

Functionality that is defined as mandatory in [1] but that is optional in the scope of SatLabs Version 1 is listed in Table 7-2:

Acronym (ID)	Description
CONV_RS	Convolutional and Reed Solomon coding support

Table 7-2: DVB-RCS required functionality which is out of SatLabs scope

Convolutional coding is viewed to be a legacy coding that was replaced by Turbo coding. Testing of this functionality is therefore determined to be outside the scope of the SatLabs Version 1.3.

Note: The defined baseline terminal functionality is not fully RCS compliant since the mandatory DVB-RCS requirement of supporting convolutional coding is not a SatLabs requirement.

### 7.3 SatLabs Qualification testing options

The list of options, defined by either DVB-RCS or SatLabs, that SatLabs compliant terminals may support and that are subject to SatLabs qualification testing is listed in Table 7-3.

Acronym (ID)	Description	Comment
MPEG_TRF	MPEG TRF burst formatting support with section packing in both directions	
COARSE_SYNC	Coarse Synchronization support	
WIDE_HOPP	RCST burst to burst frequency hopping range is 120 MHz	
FAST_HOPP	RCST supports frequency hopping between adjacent time slots	See comments. CSC field Frequency Hopping = 1
Dynamic_MF_TDMA	Dynamic MF_TDMA support	
CONTENTION_SYNC	RCST supports the use of Contention Sync slots	
MMT	Multicast PID Mapping Table signalling support.	
QPSKLOW	Low coding rates supported: 1/4, 1/3, 2/5	For ACM profile only
16APSK	16APSK support	For DVBS2 profile only.
32APSK	32APSK support	For ACM profile only
MULTITS	Multiple TS support	For ACM profile only
GSTS	Combined single GS with single TS support	For ACM profile only
ENHQOS	Support of EF+AF PHB	See [5]
PEP	Support of iPEP	See [6]
HTTP	Support of HTTP pre-fetching (single side pull)	
CHID_STRICT	The RCST supports a flag that, when set by the NCC, forces the RCSTs to strictly follow RC association when signaled through Channel_ID in the TBTP	See [5]

Table 7-3: DVB-RCS options that may be supported by SatLabs compliant terminals

In addition to these SatLabs options, terminals should implement the following feature that can be tested:

- ENHCLASSIFIER (see [5]): The Terminal should support classification criteria in addition to DSCP, as defined in [5].

In addition to these SatLabs options, terminals may also implement the following features that can be tested:

- ROUTE\_ID (see [1]): The Terminal may support insertion of Route ID in a SAC.
- RCST\_PARA (see [5]): The Terminal may support global RCST parameters for Capacity Categories,

Only terminals stating compliance with the applicable option (or feature) will be tested for this specified option (or feature). The test suite can therefore be divided into mandatory and optional test cases:

**Comments:**

- FAST\_HOPP      The Frequency Hopping field in the CSC burst informs the gateway of the frequency hopping capability:
- Value 1: the terminal has the capability to hop between two carrier frequencies (within at least a 20 MHz range) in contiguous bursts
  - Value 0: there must be at least one unused time slot between slots with different frequencies within 20 MHz.

## 7.4 Terminal Configuration

### 7.4.1 Introduction

Performing compliance and qualification testing requires the definition of a complete set of terminal configuration parameters. Ideally, the qualification testing should test every valid setting of every parameter in every combination. However, the number of options and the wide parameter range, together with small parameter increment values result in a prohibitively large set of possible terminal configurations.

The terminal parameters to be used under the qualification tests are listed in Table 7.4. The tests are to be performed with a main configuration setting: When testing a specific feature, the parameter for this specific feature is changed between each test of this feature.

The parameter configuration tables are divided into:

- Baseline parameters excluding TRF burst option parameters
- ATM configuration parameters
- MPEG option configuration parameters

In the tables below the used notation is:

X	Single value to be used for all test cases
X, (A,..N)	X to be used for all tests, A,..N to be used for testing the specific feature or function only
X ="string"	Description of the value X

The tables below list the basic parameters that must be supported. In addition the parameters specified in [5] must also be supported as specified, these parameters are not repeated below.

### 7.4.2 Parameters Overview

Parameter ID	Description
FL_FREQ	Forward Link Frequency (Ku-band)
FL_SYMBOL	Forward Link Symbol rate
FL_CODE_RATE	Forward Link Coding Rate
RL_FREQ	Return Link Frequency (Ku-band)
POP_ID	Population ID of the RCST
MAC_ADDR	MAC address of the RCST

Parameter ID	Description
RCST_CAP_FIELD	24 bit field "RCST capability" in CSC burst
PCR_LOSS_MAX	Max. time for loss of PCR without losing synchronization
SUP_RF_LEN	Default Superframe length supported by the RCST
NO_FR_SUP	Default number of frames in a Superframe supported by the RCST
NMPEG	Number of MPEG packets in an MPEG TRF burst
NATM	Number of ATM cells in a an ATM TRF burst
SAC_LEN_TRF	Length of the SAC field in TRF burst
SAC_LEN_SYNC	Length of the SAC field in SYNC burst
SYMB_RA_TRF	Symbol rates for TRF bursts
SYMB_RA_OTH	Symbol rates for ACQ, SYNC and CSC bursts
CODE_RA_TRF	Code rates for TRF bursts
CODE_RA_OTH	Code rates for ACQ, SYNC and CSC bursts
PREA_LEN_CSC	Default Preamble length in a CSC burst
PREA_SYMB_CSC	Default Preamble symbol in a CSC burst
PREA_LEN_ACQ	Default Preamble length in an ACQ burst
PREA_SYMB_ACQ	Default Preamble symbol in an ACQ burst
PREA_LEN_SYNC	Default Preamble length in a SYNC burst
PREA_SYMB_SYNC	Default Preamble symbol in a SYNC burst
PREA_LEN_TRF	Default Preamble length in a TRF burst
PREA_SYMB_TRF	Default Preamble symbol in a TRF burst
INN_CODE_TYP_CSC	Inner_code_type for CSC burst as signalled in TCT
INN_CODE_TYP_SYNC	Inner_code_type for SYNC burst as signalled in TCT
INN_CODE_TYP_TRF	Inner_code_type for TRF burst as signalled in TCT
INN_CODE_ORD_CSC	Inner_code_ordering for CSC burst as signalled in TCT
INN_CODE_ORD_SYNC	Inner_code_ordering for SYNC burst as signalled in TCT
INN_CODE_ORD_TRF	Inner_code_ordering for TRF burst as signalled in TCT
OUT_COD_CSC	Outer_coding for CSC burst as signalled in TCT

Parameter ID	Description
OUT_COD_SYNC	Outer_coding for SYNC burst as signalled in TCT
OUT_COD_TRF	Outer_coding for TRF burst as signalled in TCT
TX_RF_KU	True if the Transmit RF frequency is Ku band
TX_RF_KA	True if the Transmit RF frequency is Ka band
RX_RF_KU	True if the Receive RF frequency is Ku band
RX_RF_KA	True if the Receive RF frequency is Ka band
TIME_CORR_FLAG	Time correction flag of the Correction Message Descriptor
FREQ_CORR_FLAG	Frequency correction flag of the Correction Message Descriptor
PWR_CORR_FLAG	Power correction flag of the Correction Message Descriptor
PWR_CTRL_FLAG	Power control flag of the Correction Message Descriptor
SEC_HNDSHK_FLAG	Security Handshake Flag of the Logon Initialise Descriptor
PREFIX_FLAG	Prefix Flag of the Logon Initialise Descriptor
DULM_FLAG	Data Unit Labeling Flag of the Logon Initialise Descriptor
MINI_SLOT_FLAG	Mini-slot Flag of the Logon Initialise Descriptor
CONTENTION_FLAG	Contention Flag of the Logon Initialise Descriptor
TRF_BURST_TYPE	Traffic Burst Type of the Logon Initialise Descriptor
CONNECTIVITY	Connectivity parameter of the Logon Initialise Descriptor
SYNC_ACH_TIME_THR	Sync achieved time threshold of the SYNC assign descriptor
SYNC_MAX_TRIES	Max SYNC tries to achieve fine synchronisation
SYNC_ACH_FREQ_THR	Max frequency error to achieve fine synchronisation
INT_ACT_NETWORK_ID	Interactive Network ID parameter of the Linkage descriptor
CSC_RESP_TIMEOUT	CSC response timeout parameter of the Contention Control Descriptor
CSC_MAX_LOSSES	CSC max losses parameter of the Contention Control Descriptor
CSC_MAX_TIME_RETRY	Max time before retry parameter of the Contention Control Descriptor
ACQ_RESP_TIMEOUT	ACQ burst response timeout of the Correction Control Descriptor
SYNC_RESP_TIMEOUT	SYNC burst response timeout of the Correction Control Descriptor
ACQ_MAX_LOSSES	ACQ max losses parameter of the Correction Control Descriptor

Parameter ID	Description
SYNC_MAX_LOSSES	SYNC max losses parameter of the Correction Control Descriptor

Table 7-4: SatLabs qualification parameter overview

### 7.4.3 Baseline Parameters

The parameters listed in Table 7-5 are the baseline parameters for the qualification testing:

Parameter ID	Description	Test case value(s)	Comments
FL_FREQ	Forward Link Frequency	The frequency signaled in the NIT and RMT are randomly selected in the range 10.95 GHz .. 12.75 GHz.	This corresponds to a random IF at L-band in the range 950 – 2150 MHz..
FL_SYMBOL	Forward Link Symbol rate	Randomly selected in the range 2 – 45 Msps.	
FL_CODE_RATE	Forward Link Coding Rate	Randomly selected from the Forward Link coding rates.	Available Forward Link coding rates depend on profile: DVBS or DVBS2.
RL_FREQ	Overall Frequency Range including signal bandwidth	Randomly selected in the range 14,0 GHz .. 14,5 GHz. In addition the edge frequencies 14.0 and 14.5 GHz are tested.	This corresponds to a random IF at L-band in the range 950 – 1450 MHz..
POP_ID	Population ID of the RCST	Randomly selected.	
MAC_ADDR	MAC address of the RCST	The MAC address is extracted from the CSC burst	Input parameter for configuring the test bed.
PCR_LOSS_MAX	Max. time for loss of PCR without losing synchronization	6 seconds	
SUP_RF_LEN	Superframe duration (msec)	160 (25, 750)	
NO_FR_SUP	Number of frames in a Superframe	2 (1, 4)	
SAC_LEN_SYNC	Range of SAC field length in SYNC bursts (bytes)	10 (14)	
SYMB_RA_TRF	Symbol rates for TRF bursts (ksps)	512 (128, 256, 512, 1024, 2048, 5 random values selected with a granularity of 1 ksps)	
SYMB_RA_OTH	Symbol rates for ACQ, SYNC and CSC bursts (ksps)	512 (128, 256, 512, 1024, 2048, 5 random values selected with a granularity of 1 ksps)	
PREA_LEN_CSC	Preamble length in a CSC burst (symbols)	48 (2 random values in the range 32 – 255)	
PREA_SYMB_CSC	Preamble symbol in a CSC burst	Predefined 48 symbol sequence (One randomly selected sequence)	
PREA_LEN_ACQ	Preamble length in an ACQ burst (symbols)	48 (2 random values in the range 32 – 255)	
PREA_SYMB_ACQ	Preamble symbol in an ACQ burst	Predefined 48 symbol sequence (One randomly selected sequence with satisfactory autocorrelation properties )	
PREA_LEN_SYNC	Preamble length in a SYNC burst (symbols)	48 (2 random values in the range 32 – 255)	

Parameter ID	Description	Test case value(s)	Comments
PREA_SYMB_SYNC	Default Preamble symbol in a SYNC burst	Tests performed with predefined 48 symbol sequence and a randomly selected sequence	
PREA_LEN_TRF	Preamble length in a TRF burst (symbols)	48 (2 random values in the range 32 – 255)	
PREA_SYMB_TRF	Default Preamble symbol in a TRF burst	Tests performed with predefined 48 symbol sequence and a randomly selected sequence	
INN_CODE_TYP_CSC	Inner_code_type for CSC burst as signaled in TCT	1	only Turbo Code is tested
INN_CODE_TYP_SYNC	Inner_code_type for SYNC burst as signaled in TCT	1	only Turbo Code is tested
INN_CODE_TYP_TRF	Inner_code_type for TRF burst as signaled in TCT	1	only Turbo Code is tested
INN_CODE_ORD_CSC	Inner_code_ordering for CSC burst as signaled in TCT	0 (=natural)	
INN_CODE_ORD_SYNC	Inner_code_ordering for SYNC burst as signaled in TCT	0 (=natural)	
INN_CODE_ORD_TRF	Inner_code_ordering for TRF burst as signaled in TCT	0 (=natural)	
CODE_RA_TRF	Code rates for TRF bursts	3/4 (random selection of two additional code rates from the full range except 1/3 and 2/5)	
CODE_RA_OTH	Code rates for SYNC and CSC bursts	1/2 (random selection of 2 additional code rates within the full range)	
OUT_COD_CSC	Outer_coding for CSC burst as signaled in TCT	"10" (= CRC ON)	
OUT_COD_SYNC	Outer_coding for SYNC burst as signaled in TCT	"10" (= CRC ON)	
OUT_COD_TRF	Outer_coding for TRF burst as signaled in TCT	"11" None (turbo)	Remark: With reference to TR 101 790, CRC check shall not be used on TRF slots.
TX_RF_KU	True if the Transmit RF frequency is Ku band	True	
TX_RF_KA	True if the Transmit RF frequency is Ka band	False	
RX_RF_KU	True if the Receive RF frequency is Ku band	True	
RX_RF_KA	True if the Receive RF frequency is Ka band	False	
TIME_CORR_FLAG	Time Correction flag of the Correction Message Descriptor	1 (0)	
FREQ_CORR_FLAG	Frequency correction flag of the Correction Message Descriptor	1 (0)	
PWR_CORR_FLAG	Power Correction flag of the Correction Message Descriptor	1 (0)	

Parameter ID	Description	Test case value(s)	Comments
PWR_CTRL_FLAG	Power control flag of the Correction Message Descriptor	0 (=Eb/No measurement)	
SEC_HNDSHK_FLAG	Security Handshake flag of the Logon Initialise Descriptor	0	
CONNECTIVITY	Connectivity parameter in the Logon Initialise Descriptor	0 (=IP)	
SYNC_ACH_TIME_THR	Sync achieved time threshold of the SYNC assign Descriptor	400 % of symbol length (15,6 us .. 1,0 us)	
SYNC_MAX_TRIES	Max SYNC tries to achieve fine synchronization	One value randomly selected in the range 5-50	
SYNCH_ACH_FREQ_THR	Max frequency error to achieve fine synchronization	1000 Hz	
INT_ACT_NETWORK_ID	Interactive Network ID parameter of the Linkage descriptor	Extracted from Linkage Descriptor in RMT	The terminal shall find the Interactive Network ID automatically based on the configured Population ID
CSC_RESP_TIMEOUT	CSC response timeout parameter of the Contention Control Descriptor	One value randomly selected in the range 1 - 5-seconds	
CSC_MAX_LOSSES	CSC max losses parameter of the Contention Control Descriptor	One value randomly selected in the range 5 – 255	
CSC_MAX_TIME_RETRY	CSC max time before retry parameter of the Contention Control Descriptor	One value randomly selected in the range 1 - 5-seconds	
ACQ_RESP_TIMEOUT	ACQ burst response timeout parameter of the Contention Control Descriptor	One random value within the range 0,5 .. 5 sec smaller or equal to "repeat period" in ACQ Assign descriptor	Only applicable for COARSE option
SYNC_RESP_TIMEOUT	SYNC burst response timeout parameter of the Contention Control Descriptor	One random value within the range 0,5 .. 5 sec smaller or equal to "repeat period" in SYNC Assign descriptor	
ACQ_MAX_LOSSES	ACQ burst max losses parameter of the Contention Control Descriptor	One random value in the range 5 .. 20	Only applicable for COARSE option
SYNC_MAX_LOSSES	SYNC burst max losses parameter of the Contention Control Descriptor	One random value in the range 5 .. 50	

Parameter ID	Description	Test case value(s)	Comments
NUM_TS_FR	Number of time slots per frame	120 (10, 1120)	1120 time slots will be allocated on 2 frequencies. Remark: The number of 1128 results from the maximum capacity of frames when following the default settings for TRF slots (as reported in this document) and having a standard frame composition with few CSC, ACQ and SYNC bursts and filling the rest of the frame with TRF bursts (for the maximum superframe length as given in this document).
FREQ_HOP-FIELD	Frequency hopping field in CSC slots (fast_hop, slow_hop)	Depends on terminal capability	Terminal parameter signalled in CSC

Table 7-5: SatLabs qualification common parameter values

### 7.4.4 ATM parameters

The parameters listed in Table 7-6 are only applicable for the ATM configuration. Parameters related to MPEG are set to N/A (not applicable). DC means “Don’t Care”.

Parameter ID	Description	Test case value range	Comments
RCST_CAP_FIELD	<ul style="list-style-type: none"> <li>– Security mechanism</li> <li>– SNMP</li> <li>– ATM Connectivity</li> <li>– MPEG2-TS TRF</li> <li>– RCST boards</li> <li>– RCST ACQ</li> <li>– Multi_IDU</li> <li>– S/W Version</li> <li>– Freq Hopping Range</li> <li>– MF-TDMA</li> <li>– RCST Class</li> <li>– Route_ID capable</li> <li>– RCST Mode</li> </ul>	<ul style="list-style-type: none"> <li>DC</li> <li>DC</li> <li>DC</li> <li>DC</li> <li>00</li> <li>0 or 1</li> <li>DC</li> <li>Any value. System dependent.</li> <li>00</li> <li>DC</li> <li>DC</li> <li>DC</li> <li>00 or 01 or 10</li> </ul>	
NMPEG	Number of MPEG packets in a MPEG TRF burst	N/A	
NATM	Number of ATM cells in a ATM TRF burst	2 (2, 4)	
SAC_LEN_TRF	Range of SAC field length in prefixed TRF burst ( bytes)	4	
PREFIX_FLAG	Prefix flag of the Logon Initialise Descriptor	1 (0)	
DULM_FLAG	Data Unit Labelling Flag of the Logon Initialise Descriptor	0	
MINI_SLOT_FLAG	Mini-slot flag of the Logon Initialise Descriptor	1 (0)	
CONTENTION_FLAG	Contention Flag of the Logon Initialise Descriptot	0 (1)	
TRF_BURST_TYPE	Traffic Burst Type of the Logon Initialise Descriptor	0 (=ATM)	

Table 7-6: SatLabs qualification parameter values for the Basic ATM profile

## 7.4.5 MPEG Option Parameters

The parameter list in Table 7-7 specifies the complete set of test parameters for the MPEG option. Parameters related to ATM are set to N/A (not applicable). DC means "Don't Care".

Parameter ID	Description	Test case value(s)	Comments
RCST_CAP_FIELD	<ul style="list-style-type: none"> <li>– Security mechanism</li> <li>– SNMP</li> <li>– ATM Connectivity</li> <li>– MPEG2-TS TRF</li> <li>– RCST boards</li> <li>– RCST ACQ</li> <li>– Multi_IDU</li> <li>– S/W Version</li> <li>– Freq Hopping Range</li> <li>– MF-TDMA</li> <li>– RCST Class</li> <li>– Route_ID capable</li> <li>– RCST Mode</li> </ul>	DC DC DC 1 00 0 or 1 DC Any value. System dependent. 00 DC DC DC 00 or 01 or 10	
NMPEG	Number of MPEG packets in a MPEG TRF burst	1	
NATM	Number of ATM cells in a ATM TRF burst	N/A	
SAC_LEN_TRF	Length of the SAC field in TRF burst	0	
PREFIX_FLAG	Prefix Flag of the Logon Initialise Descriptor	0	
DULM_FLAG	Data Unit Labeling Flag of the Logon Initialise Descriptor	0	
MINI_SLOT_FLAG	Mini-slot Flag of the Logon Initialise Descriptor	1	
CONTENTION_FLAG	Contention Flag of the Logon Initialise Descriptor	0 (1)	
TRF_BURST_TYPE	Traffic Burst Type in the Logon Initialise Descriptor	1 (=MPEG)	

Table 7-7: SatLabs qualification parameter values for the MPEG option

## 8 Qualification Testing

### 8.1 Introduction

The main objective of the SatLabs qualification testing is to document compliance with:

- Critical system interoperability issues at the IP and RCS protocol level
- QoS functionality
- Harmonised management and control functionality

The test plan is described in the document SatLabs Terminal certification Test Plan [3]. Minimising test system complexity, equipment investments and qualification test time are also important to enable a feasible qualification scheme. Issues that are outside the scope of the qualification testing are:

- Functional and performance tests of the outdoor unit air interface
- Performance testing of the Indoor unit
- Control signals provided by the indoor unit to control the outdoor unit

The defined scope allows the testing to take place at IF. For terminals with the frequency reference residing in the IDU, it is normally sufficient to test the IDU alone. For terminals with the frequency reference in the ODU, the ODU may be included in the test to facilitate the operation of the IDU.

The terminals shall have the ability to set the terminal in a mode compliant with the SatLabs qualification test set-up as described in this document.

### 8.2 Terminal Qualification Test Set-up

The Test System is connected to the IF interface between Indoor and Outdoor Units. If necessary, the Outdoor Unit can be connected to the Indoor Unit. The test set-up for testing the Indoor Unit alone, and testing the Indoor Unit connected to the Outdoor Unit, is shown in Figure 8-1.

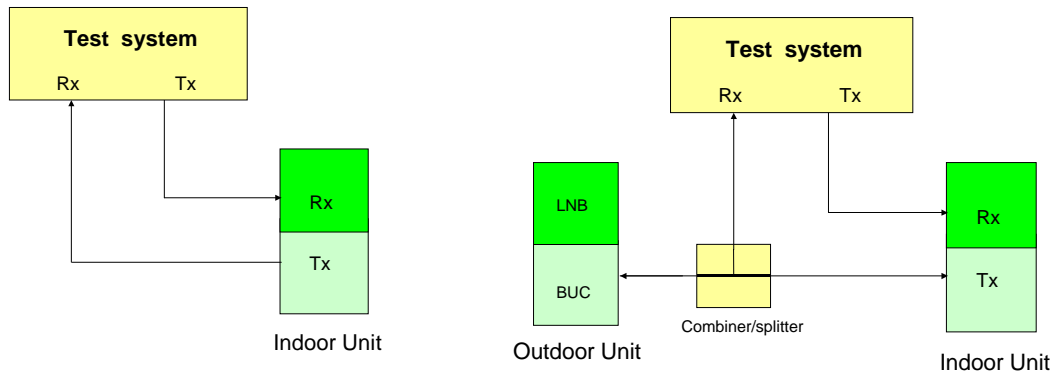

Figure 8-1: Qualification test set-ups:  
 - testing of Indoor Unit only  
 - testing of Indoor Unit connected to the Outdoor Unit

The test system Tx port outputs the DVB-RCS forward link stream at the configured frequency. The test system delivers the MPEG2 transport stream carrying relevant SI-tables as well as IP traffic. The terminal transmits RCS bursts on the terminal Tx port that are received on the Test System Rx port. The test system demodulates, decodes and evaluates the received bursts from the terminal. The frequency and timing accuracy is also measured.

The test system is connected to the IF interface between the IDU and the ODU. If necessary the ODU can be connected to the IDU by using a combiner/splitter as shown in Figure 8.1.

**Test System Tx port**

The IDU Rx port is connected to the Test System Tx port. The Tx port outputs the forward link DVB-S signal configured as defined in the applicable test case. The test system ignores the 22 kHz signal and DC voltage output by the IDU.

**Test System Rx port**

The IDU Tx port is connected to the Test System Rx port, if necessary via a combiner/splitter also allowing the ODU to remain connected to the IDU under test. This combining/splitter network shall not interfere with the communication between IDU and ODU, shall pass DC from the IDU to the ODU and shall also pass the reference signal from the ODU to the IDU. The test system will only evaluate the received RF bursts from the IDU.

### 8.3 Test System Interface Specifications

The specifications for the test system ports are given in Table 8-1.

<b>TX-port parameters</b>	<b>Value</b>	<b>Comments</b>
TX frequency range	950-2150 MHz	
TX output power	- 50 dBm to – 20 dBm	
TX output impedance	75 ohm	
Tx port connector	F or BNC	
Modulation	DVB-S and DVB-S2 See 6.4.17	DVB-S and DVB-S2
Symbol Rate	2 - 45 Msymbols/s, variable in 100 symbol/s	
Clock accuracy (NCR, symbol rate)	10e-8	
Code Rates	See 6.4.17	DVB-S and DVB-S2
Signal conditions: channel coding, shaping	See 6.4.17	
<b>RX-port parameters</b>	<b>Value</b>	<b>Comments</b>
RX frequency range	950-1750 MHz 2250-3000 MHz	
Input signal level	- 20 dBm – 0 dBm	
Signal conditions: channel coding, shaping	EN 301 790	

Table 8-1: Test system interface specifications

## Appendix A - Definition of the Multicast PID Mapping Table

The Multicast PID Mapping Table defines the PIDs associated with multicast IP addresses. It consists of sections called Multicast\_to\_PID\_map, which are private sections as defined in the MPEG-2 Systems standard.

The most recently transmitted version of the multicast\_to\_PID\_map section with the current\_next\_indicator set to a value of '1' shall always apply to the current data within the Transport Stream. Any changes to the multicast sessions carried within the Transport Stream shall be described in an updated version of the MPEG Multicast Mapping Table carried in Transport Stream. A new version of a multicast\_to\_PID\_map becomes valid when the last byte of that section with a new version\_number and with the current\_next\_indicator set to '1' is processed.

Syntax	No. of bits	Notes
Multicast_to_PID_map {		
table_id	8	'0xC0'
Section_syntax_indicator	1	'1'
Private_indicator	1	
reserved	2	'11'
Private_section_length	12	
table_id_extension	16	
reserved	2	
Version_number	5	
Current_next_indicator	1	
Section_number	8	
last_section_number	8	
for (i=0; i<N; i++) {		
IPv6_flag	1	
reserved	2	
elementary_PID	13	
for (l=0; l<4; l++) {		
IPv4_address	8	
}		
if (IPv6_flag == '1') {		
for (i=0; i<6; i++) {		
IPv6_address	16	
}		
}		
}		
CRC_32	32	
}		

Table A-1: Multicast PID Mapping Table (DVB format)

**table\_id:** an 8-bit field which identifies the MPEG Private Table this section belongs to. Here, the value is 0xC0.

**section\_syntax\_indicator:** a 1-bit indicator. When set to '1', it indicates that the private section follows the generic section syntax beyond the `private_section_length` field. When set to '0', it indicates that the `private_data_bytes` immediately follow the `private_section_length` field.

**private\_indicator:** a 1-bit user definable flag; it is not used

**reserved:** these bits may be used in the future; all reserved bits shall be set to '1'

**private\_section\_length:** a 12-bit field specifying the number of remaining bytes in the section immediately following the `private_section_length` field up to the end of the `private_section`. The value in this field shall not exceed 4093 (0xFFD).

**table\_id\_extension:** a 16-bit field; it is not used.

**version\_number:** a 5-bit field that defines the version number of the `private_section`. The `version_number` shall be incremented by 1 modulo 32 when a change in the information carried within the `private_section` occurs. When the `current_next_indicator` is set to '0', then the `version_number` shall be that of the next applicable `private_section` with the same `table_id` and `section_number`.

**current\_next\_indicator:** a 1-bit field, which when set to '1' indicates that the `private_section` sent is currently applicable. When the `current_next_indicator` is set to '1', then the `version_number` shall be that of the currently applicable `private_section`. When the bit is set to '0', it indicates that the `private_section` sent is not yet applicable and shall be the next `private_section` with the same `section_number` and `table_id` to become valid.

**section\_number:** an 8-bit field that gives the number of the `private_section`. The `section_number` of the first section in a private table shall be 0x00. The `section_number` shall be incremented by 1 with each additional section in this private table.

**last\_section\_number:** an 8-bit field that specifies the number of the last section (that is, the section with the highest `section_number`) of the private table of which this section is a part.

**IPv6\_flag:** a one-bit field that specifies whether IPv6 addressing is used. When set to '0', it indicates that IPv4 (32-bit address space) addressing is used.

**elementary\_PID:** 13-bit field specifying the PID of the Transport Stream packets which carry the associated multicast data

**IPv4\_address:** a 32-bit field that specifies the multicast IP address for data carried in the elementary\_PID. The IP address is fragmented into four fields of 8 bits, where `IPv4_address[0]` containing the most significant byte of the IP address, while `IPv4_address[3]` contains the least significant byte of the IP address.

**IPv6\_address:** a 96-bit field that specifies the multicast IP address for data carried in the elementary\_PID. The IP address is fragmented into six fields of 16 bits, where `IPv6_address[0]` containing the most significant 16 bit field of the IP address, while `IPv6_address[5]` contains the least significant 16 bit field of the IP address.

Together with `IPv4_address`, `IPv6_address` will yield the following IP address format:  
`XX:XX:XX:XX:XX:XX:d.d.d.d`,

where "XX" is the hexadecimal value of the high-order 16-bit pieces of the address and "d" is the decimal value of the low-order bit pieces of the address. See RFC 4291 [7].

**CRC\_32:** a 32-bit field that contains the CRC value that gives a zero output of the registers in the decoder defined in Annex B of EN 300 468 [8] after processing the entire private section.

## Appendix B - NCR optional payload recommendations

### B.1 Background

Implementation of the optional payload field in the PCR Insertion TS packet provides a generic method for the distribution of synchronization information critical to the operation of complex satellite network architectures, comprising multiple forward link and return link satellites and multiple gateways. The method is equally applicable to systems where a single satellite supports both the forward and return links; it is this network scenario that is of interest to the SatLabs Qualification.

It is a system decision whether or not to use the optional payload. The RCST shall determine the presence of the payload and use the appropriate values if found within it. If the optional payload is absent, the RCST shall assume zero values for the delays that can be communicated in the optional payload.

The following description on timing references will involve the key elements of the Satellite Interactive Network:

- **Network Control Centre (NCC):** The NCC provides Control and Monitoring Functions (CMF). It generates control and timing signals for the operation of the Satellite Interactive Network to be transmitted by one or several Feeder Stations.
- **Traffic Gateway (TG):** The TG receives the RCST return signals, provides accounting functions, interactive services and/or connections to external public, proprietary and private service providers (data bases, pay-per-view TV or video sources, software download, tele-shopping, tele-banking, financial services, stock market access, interactive games etc.) and networks (Internet, ISDN, PSTN, etc.).
- **Feeder Station (FS):** The Feeder transmits the forward link signal, which is a standard satellite digital video broadcast (DVB-S) uplink, onto which are multiplexed the user data and/or the control and timing signals needed for the operation of the Satellite Interactive Network.

The optional payload is used by the RCST by scanning the contents of the NCR payload section matching the `satellite_id`, `NCC_id` and `gateway_id` to values it has received during forward link acquisition via the Satellite Forward Link Descriptor and Satellite Return Link Descriptor. After finding a match the RCST adds the delay values found in the appropriate loop of the optional payload (see below for specific details) to its calculated delay values to/from the satellite. At the NCC, the optional payload field is appended to the PCR Insertion TS packet. The network operator inserts the appropriate delay values for the NCC to satellite path and the satellite to gateway path. If these delay values are not required in the particular network implementation zero values can be inserted, or the optional payload can be omitted.

The DVB-RCS standard does not explicitly state how the NCC shall establish the timing reference plane in the Satellite Interactive Network. As a consequence, different manufacturers can establish the reference plane in different ways. For instance some manufacturers may adjust the value of the PCR packet prior to transmission on the forward link, so that it

appears to originate at the satellite. Other approaches may include varying the start of superframe detection in the traffic gateway to match the changing delay caused by the satellite motion. With this variety in NCC/gateway implementations the value of the optional PCR Insertion TS packet payload section can be used as a simple means to convey critical delay values necessary to permit any SatLabs certified terminal to operate on any DVB-RCS NCC/traffic gateway.

## B.2 Implementation of the Optional Payload Field in the PCR Insertion TS Packet

The syntax of the optional PCR Insertion TS packet payload section is provided in a Table within Section 8.5.5.6.3 of the DVB-RCS standard [1]. The table is reproduced below with comments added to the definitions of the parameters. The table includes forward link and return link combinations. A forward link combination identifies the satellite, the NCC and the propagation delay between the NCC and the satellite. A return link combination identifies the satellite, the traffic gateway and the propagation delay between the satellite and the traffic gateway. The RCST shall use the two propagation delays for the applicable satellite/NCC/gateway combination to adjust its delay calculation, prior to transmission of the CSC burst at initial logon. The total delay value that the RCST must consider for its calculation is the sum of those provided for the forward and return links.

It is this feature of the optional payload, i.e., carrying separate delays for multiple return link and forward link combinations, that is vital to achieving synchronization in multiple-satellite, multiple-gateway architectures. In the case of the SatLabs scenario, however, the return link satellite and forward link satellite are assumed to be the same, and the gateway is part of the unique hub which also includes the NCC and feeder station functionality. Even in this scenario, the optional payload is still useful, because it allows the setting of the reference plane either at the satellite or at the NCC.

The detailed semantics of the optional PCR Insertion TS packet payload section is shown below (Table B-1). Additional comments (in bold) are included within the syntax description to provide further clarification.

Syntax	No of bits		Information mnemonic
	Reserved	Information	
PCR Insertion TS packet payload section () {			
SI_private_section_header		64	-
forward_link_combinations		8	uimsbf
for (i=0; i<forward_link_combinations; i++){			
satellite_id		8	uimsbf
NCC_id		8	uimsbf
propagation_delay }		32	upcrmsf
return_link_combinations		8	uimsbf
for (i=0; i<return_link_combinations; i++) {			
satellite_id		8	uimsbf
gateway_id		8	uimsbf
propagation_delay }		32	upcrmsf
descriptor_length		8	uimsbf
for(i=0; i<N; i++) {			
descriptor()			
CRC_32		32	rpchof
}			

Table B-1: Syntax of the optional PCR Insertion TS packet payload section

- SI\_private\_section\_header: This is the standard SI private section header defined in Table 11, and occupies a total of 64 bits;
- forward\_link\_combinations: This 8 bit field defines one less than the number of all applicable NCC to satellite combinations on the forward link. A zero count indicates one loop (Note 2).
- satellite\_id: This 8 bit field defines the identifier of the satellite end of one combination. The satellite\_id is assigned by the system administrator. The RCST shall match this satellite\_id with the satellite\_id provided in the Satellite Forward Link Descriptor (subclause 8.5.5.10.11).
- NCC\_id: This 8 bit field defines the identifier of the NCC end of one combination. The NCC\_id is assigned by the system administrator. The RCST shall match this NCC\_id with the NCC\_id provided in the Satellite Forward Link Descriptor (subclause 8.5.5.10.11)
- propagation\_delay: This 32 bit field defines the propagation\_delay between NCC and satellite as a PCR count. For the forward link it is the delay from NCC to satellite while for the return link it is the delay from satellite to Gateway. The 32 bits corresponds to a maximum delay of 93.2 s. RCSTs may use this information to compute delays. When the optional PCR TS packet payload section is present, and the forward link combination matches the satellite\_id and NCC\_id in use, the RCST shall add the value of the delay included to the result of the delay calculation based on the RCST position and the SPT (subclause 8.5.5.5 Satellite Position Table (SPT)); i.e., the transmission instant shall be advanced by an amount equal to the value of the forward link propagation\_delay, compared to that determined without considering the propagation\_delay. The value of the delay included in the optional PCR Insertion TS packet payload section is dependent on the implementation of the NCC and is outside the scope of SatLabs. When the optional PCR TS packet payload section is present, and the return link combination matches the satellite\_id and gateway\_id in use, the RCST shall add the value of the delay included to the delay calculation based on the RCST position and the SPT (subclause 8.5.5.5 Satellite Position Table (SPT)). When applicable values for both forward and return link are present, the correction shall be the sum of the two values. (Note 1) (Note 3)
- return\_link\_combinations: This 8 bit field defines one less than the number of all applicable satellite to Gateway combinations on the return link. A zero count indicates one loop (Note 2).
- Gateway\_id: This 8 bit field defines the identifier of the Gateway end of one combination. The Gateway\_id is assigned by the system administrator. The RCST shall match this gateway\_id with the gateway\_id provided in the Satellite Return Link Descriptor (subclause 8.5.5.10.12).
- descriptor\_length: This 8 bit field gives the total length in bytes of future descriptors;
- CRC\_32: This is a 32 bit field that contains the CRC value that gives a zero output of the registers in the decoder defined in annex B of EN 300 468 [4] after processing the entire section.

**Notes:**

1. For test purposes, non-zero delay values are to be introduced in the forward link between the Test Set and the IDU under test in the forward direction and in the return direction. These non-zero values are then to be inserted in the optional PCR Insertion TS packet payload. This should result in CSC burst arriving at the test system's gateway at the same time as if no delays and corrections were present.
2. There is an inconsistency in the standard between Table 22 and the semantics description. According to the syntax, a zero value indicates zero passes over the loop. The agreed interpretation is that a value of  $X$  corresponds to  $X$  passes over the loop. The test scenario assumes a single satellite supporting both the forward and return link traffic, so the forward link loop count and the return link loop count shall both be set to one.
3. If the values provided correspond to the actual delays between NCC and satellite and between satellite and gateway respectively, the corresponding correction will place the reference plane at the gateway. If zero values are transmitted, or if no applicable correction values are provided, the reference plane will be located at the satellite. The location of the reference plane is a system design decision.